

**Materials**

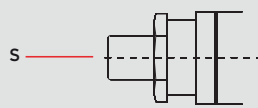
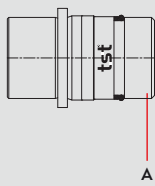

**SCREW LOCKING**

**Material Code**

A = AISI 303

S = AISI 420



0 - 180 bar



-26°C to + 200°C (FPM)

**Shut Off Type**



# FF

Water 5m/sec. 20°C

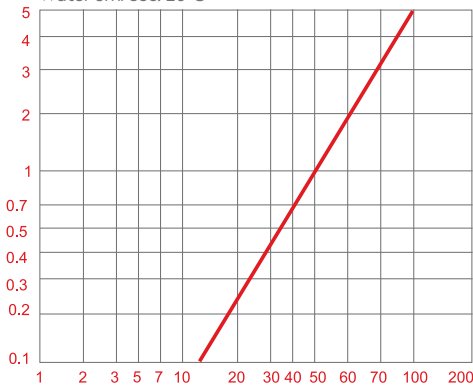

Water Flow l / min  
Pressure Drop (bar)

**QUICK COUPLINGS SCHNELLKUPPLUNGEN**

with female thread

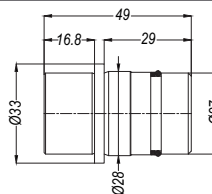

Part no.

MK104.10 DGB 00

**PLUGS STECKNIPPEL**

with female thread

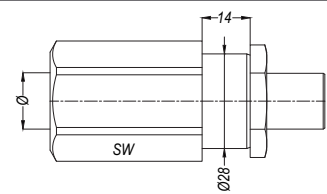

Part no.

Ø

SW

104.10 DUB 17 MP	BSP 3/8"	32
104.10 DUB 21 MP	BSP 1/2"	32
104.10 NUB 17 MP	NPT 3/8"	32
104.10 NUB 21 MP	NPT 1/2"	32

**Options**

PD



MMK  
COUPLING

OV 262 - 01905 - 88  
OV 178 - 01280 - 88  
OV 178 - 02195 - 88

MM  
PLUG

OV 190 - 00930 - 88  
OV 178 - 02195 - 88  
OV 262 - 01715 - 88

**Applications**

- Hydraulic Circuits

# DN

# 10 mm

**Compatible with**

MULTICOUPLINGS

MULTIKUPPLUNGEN

3 ↔ 3

# SERIE 108M-HF

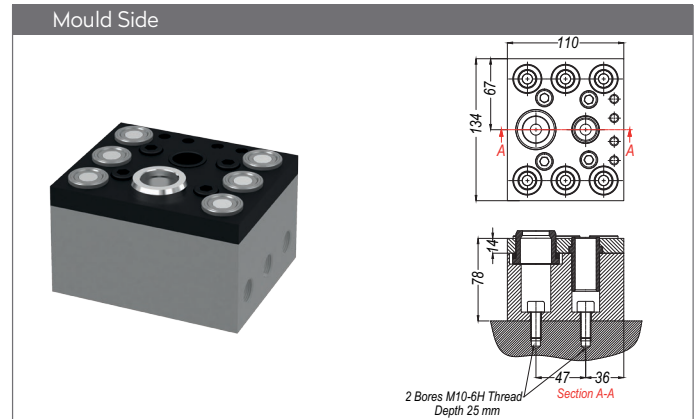
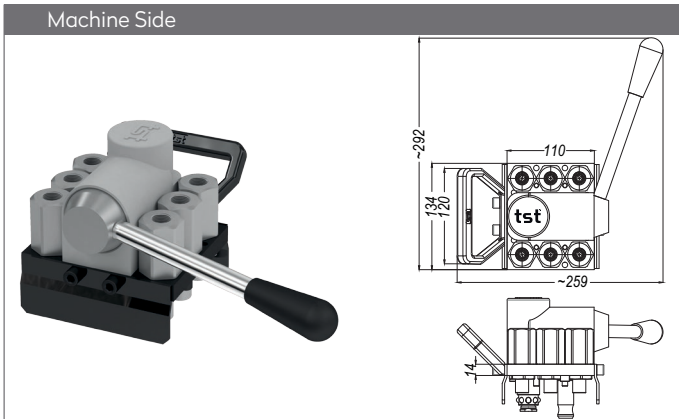

Part No.	Unit	Ø
	-	without plugs
MM108.06 G17-HF	6	104.10 DUB 17MP (3/8" BSP)
MM108.06 G21-HF	6	104.10 DUB 21MP (1/2" BSP)
MM108.06 N17-HF	6	104.10 NUB 17MP (3/8" NPT)
MM108.06 N21-HF	6	104.10 NUB 21MP (1/2" NPT)
MM108.06 U14-HF	6	104.10 UUB 14MP (9/16" UNF)
MM108.06 U19-HF	6	104.10 UUB 19MP (3/4" UNF)

Part No.	Unit	Ø
	-	without couplings
MK108.06 G17-HF	6	MK104.10 DGB 00
	6	3/8" BSP female thread holes on sides
MK108.06 G21-HF	6	MK104.10 DGB 00
	6	1/2" BSP female thread holes on sides
MK108.06 N17-HF	6	104.10 NGB 17MP (3/8" NPT)
	6	3/8" NPT female thread holes on sides
MK108.06 N21-HF	6	104.10 NGB 21MP (1/2" NPT)
	6	1/2" NPT female thread holes on sides
MK108.06 U14-HF	6	104.10 UUB 14MP (9/16" UNF)
	6	9/16" UNF female thread holes on sides
MK108.06 U19-HF	6	104.10 UUB 19MP (3/4" UNF)
	6	3/4" UNF female thread holes on sides

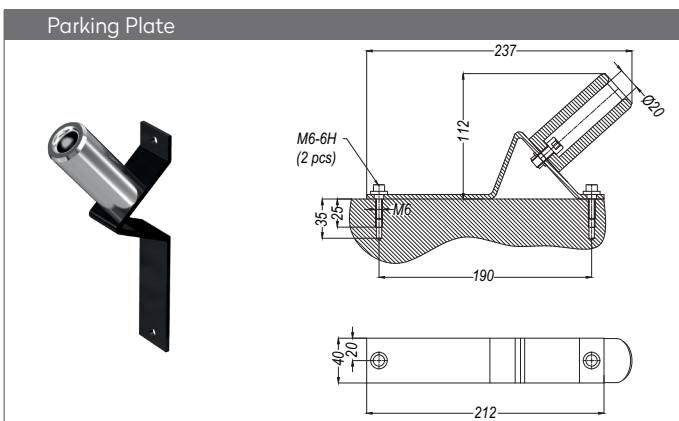

Part No.
MM108.06 P

# SERIE 108M-HF

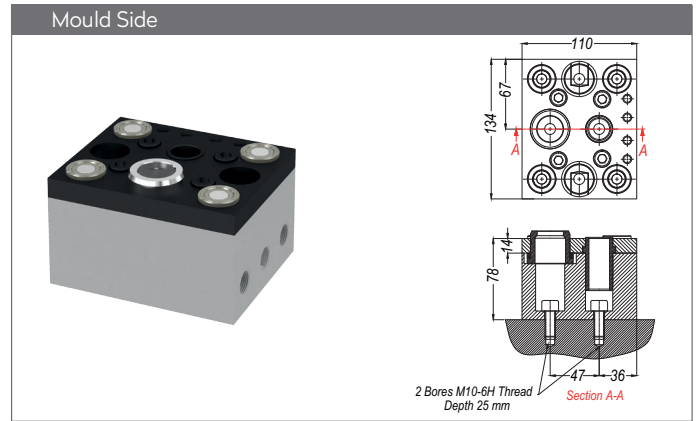
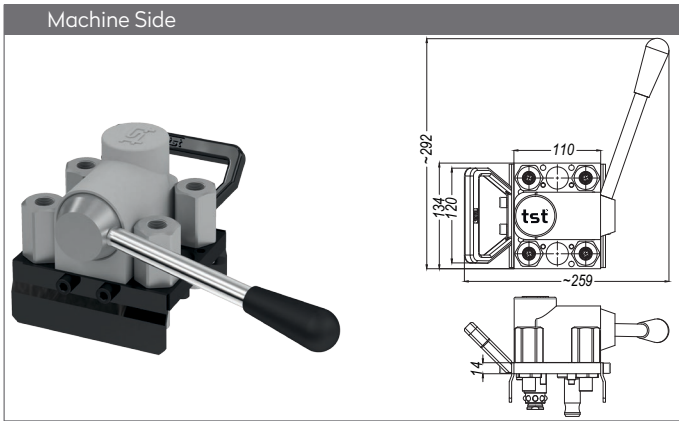

Part No.	Unit	Ø
	-	without plugs
MM108.04 G17-HF	4	104.10 DUB 17MP (3/8" BSP)
MM108.04 G21-HF	4	104.10 DUB 21MP (1/2" BSP)
MM108.04 N17-HF	4	104.10 NUB 17MP (3/8" NPT)
MM108.04 N21-HF	4	104.10 NUB 21MP (1/2" NPT)
MM108.04 U14-HF	4	104.10 UUB 14MP (9/16" UNF)
MM108.04 U19-HF	4	104.10 UUB 19MP (3/4" UNF)

Part No.	Unit	Ø
	-	without couplings
MK108.04 G17-HF	4	MK104.10 DGB 00
	6	3/8" BSP female thread holes on sides
MK108.04 G21-HF	4	MK104.10 DGB 00
	6	1/2" BSP female thread holes on sides
MK108.04 N17-HF	4	MK104.10 DGB 00
	6	3/8" NPT female thread holes on sides
MK108.04 N21-HF	4	MK104.10 DGB 00
	6	1/2" NPT female thread holes on sides
MK108.04 U14-HF	4	MK104.10 DGB 00
	6	9/16" UNF female thread holes on sides
MK108.04 U19-HF	4	MK104.10 DGB 00
	6	3/4" UNF female thread holes on sides

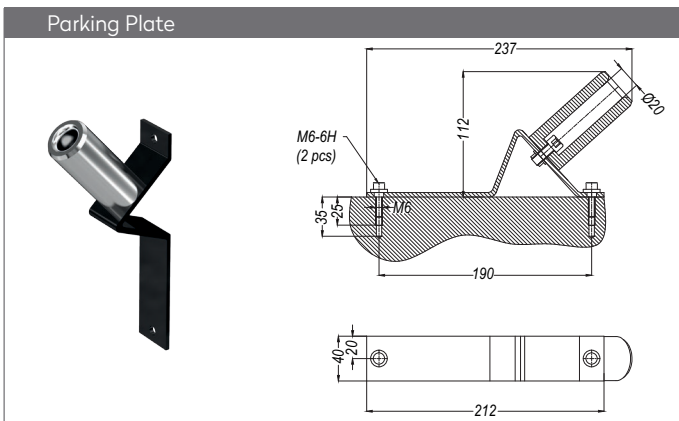

Part No.
MM108.06 P

MULTICOUPLINGS  
 MULTIKUPPLUNGEN

1 ↔ 1

# SERIE 108M-HF

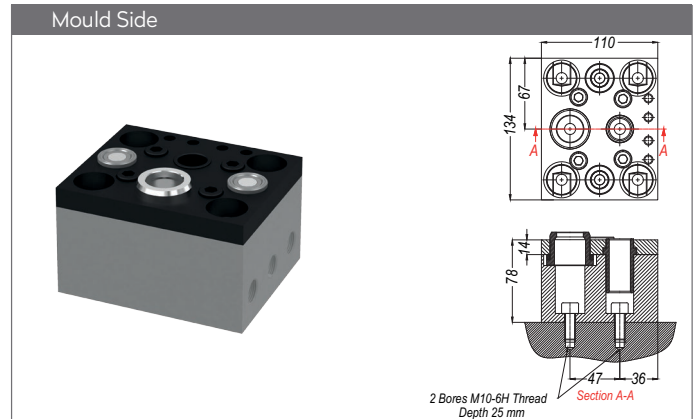
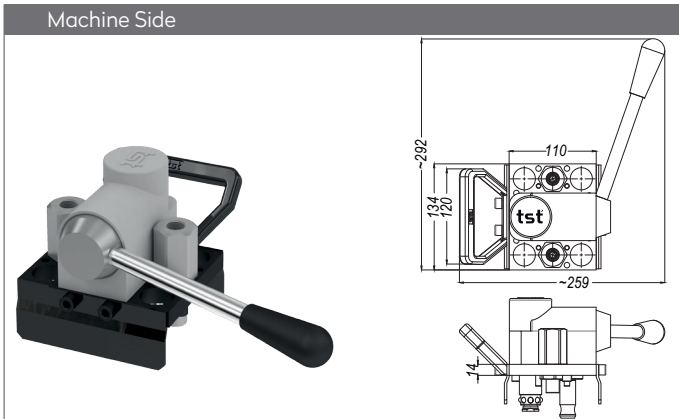

Part No.	Unit	Ø
	-	without plugs
MM108.02 G17-HF	2	104.10 DUB 17MP (3/8" BSP)
MM108.02 G21-HF	2	104.10 DUB 21MP (1/2" BSP)
MM108.02 N17-HF	2	104.10 NUB 17MP (3/8" NPT)
MM108.02 N21-HF	2	104.10 NUB 21MP (1/2" NPT)
MM108.02 U14-HF	2	104.10 UUB 14MP (9/16" UNF)
MM108.02 U19-HF	2	104.10 UUB 19MP (3/4" UNF)

Part No.	Unit	Ø
	-	without couplings
MK108.02 G17-HF	2	MK104.10 DGB 00
	6	3/8" BSP female thread holes on sides
MK108.02 G21-HF	2	MK104.10 DGB 00
	6	1/2" BSP female thread holes on sides
MK108.02 N17-HF	2	MK104.10 DGB 00
	6	3/8" NPT female thread holes on sides
MK108.02 N21-HF	2	MK104.10 DGB 00
	6	1/2" NPT female thread holes on sides
MK108.02 U14-HF	2	MK104.10 DGB 00
	6	9/16" UNF female thread holes on sides
MK108.02 U19-HF	2	MK104.10 DGB 00
	6	3/4" UNF female thread holes on sides

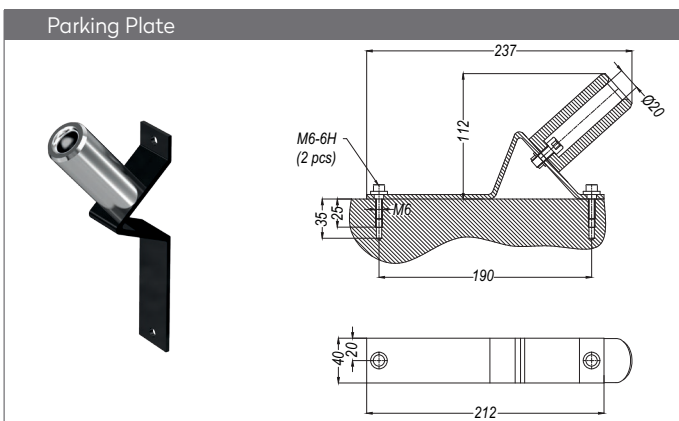

Part No.
MM108.06 P