

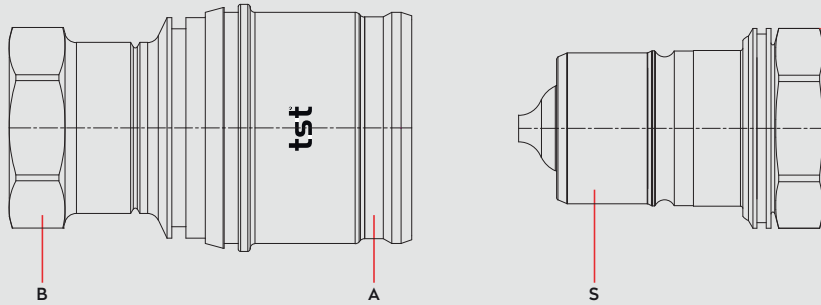



Materials



Material Code

A = AISI 316
B = Brass Chemical Nickel Plated
S = AISI 420



0 - 16 bar



-26° to + 200°C (FPM)

Shut Off Type



COUPLING
OV 353 - 03490
OV 353 - 06390

PLUG
OV 353 - 03490

DN 37 mm

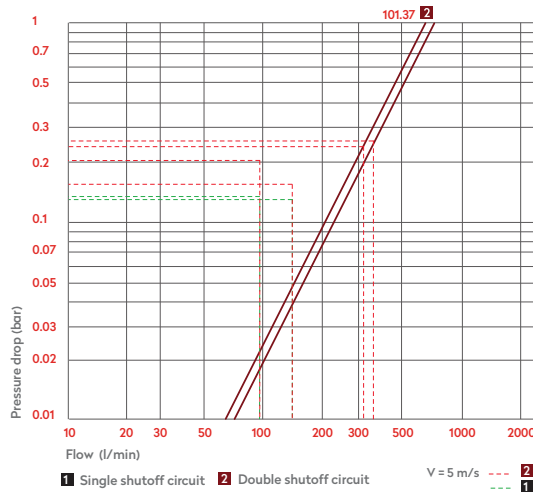

Options

E2

FFKM
please ask

EPDM

Id. Ring

Applications

- Cold - hot fluid circuits
- Temperature control

Compatible with



MOULD COOLING COUPLINGS
KÜHLUNGSELEMENTE FÜR WERKZEUGE

SERIE 101.37

QUICK COUPLINGS SCHNELLKUPPLUNGEN

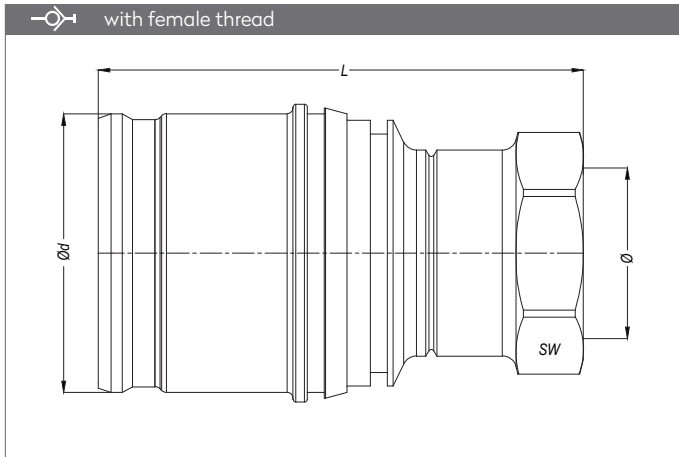

Part no.	Ø	DN	Ød	L	SW
101.37 DGB 60	BSP 2"	38	104.8	170.7	75

PLUGS STECKNIPPEL

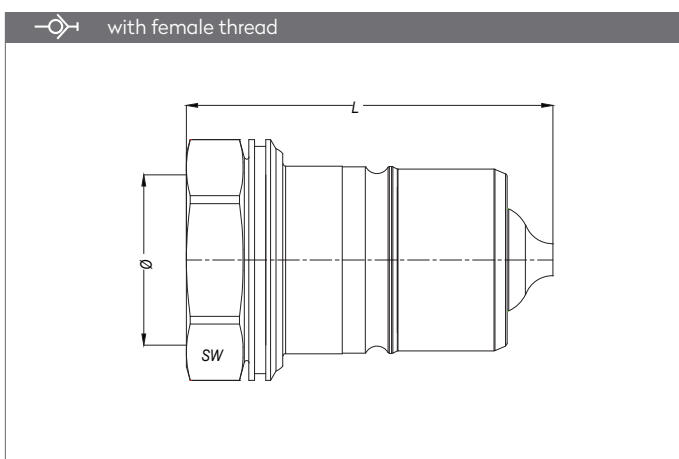

Part no.	Ø	DN	L	SW
101.37 DUB 60	BSP 2"	38	129	75