

MOULD ACCESSORIES

Deflection Baffles

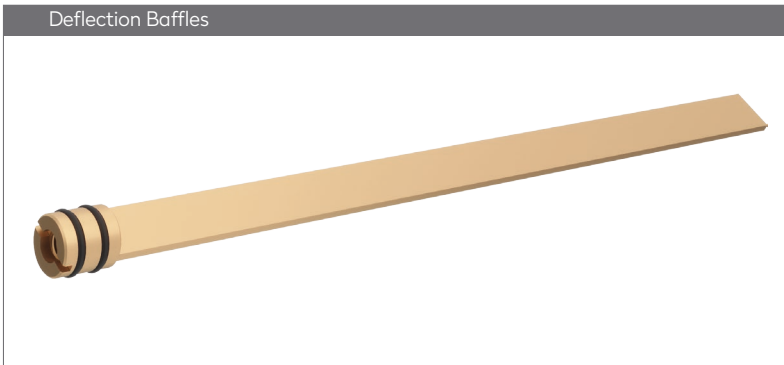

Part No.	Ød1	Ød2	Ø	Ød	L	L1	L2	S
LKS 10 x 180	10	12	M6x1	11.7	180	13	193	2
LKS 15 x 150	15	16	M8x1.25	15.7	250	16	266	2.4
LKS 20 x 300	20	22	M12x1.75	21.7	300	20	320	2.4
LKS 25 x 390	25	26	M16x2	25	390	22	412	2.4

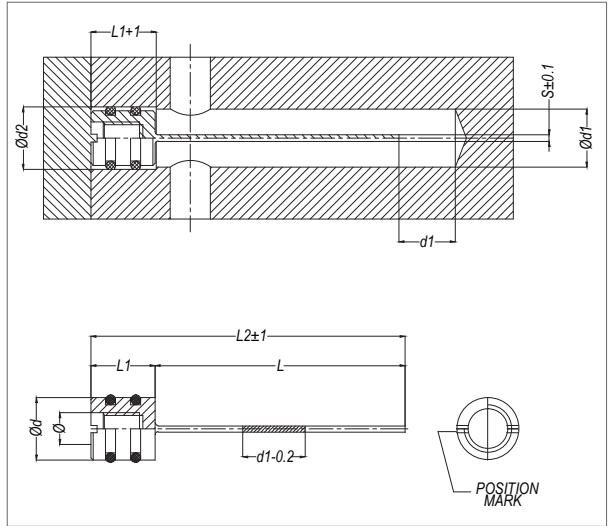

Deflection Baffles



Part No.	L	L1	L2	L3	L4	Ød	Ød1	Ød2	Ød3	Ød4	Ød5	S
BKS 10/2.6x0.3x100	100	16	9	3.5	2.5	2.6	4	10	2	4	2	0.3
BKS 10/2.6x0.3x200	200	16	9	3.5	2.5	2.6	4	10	2	4	2	0.3
BKS 10/3x0.3x100	100	16	9	3.5	2.5	3	5	10	2.4	4	2	0.3
BKS 10/3x0.3x200	200	16	9	3.5	2.5	3	5	10	2.4	4	2	0.3
BKS 10/4x0.5x100	100	16	9	3.5	2.5	4	6	10	3	4	2	0.5
BKS 10/4x0.5x200	200	16	9	3.5	2.5	4	6	10	3	4	2	0.5
BKS 12/5x0.5x160	160	18	9	4.5	2.5	5	8	12	4	6	2	0.5
BKS 12/5x0.5x315	315	18	9	4.5	2.5	5	8	12	4	6	2	0.5
BKS 16/6x0.5x160	160	18	9	6	2.5	6	12	16	5	6	2	0.5
BKS 16/6x0.5x315	315	18	9	6	2.5	6	12	16	5	6	2	0.5
BKS 18/8x1x160	160	18	9	7	2.5	8	14	18	6	6	2	1
BKS 18/8x1x315	315	18	9	7	2.5	8	14	18	6	6	2	1
BKS 20/10x1x160	160	20	10	8	2.5	10	16	20	8	8	3	1
BKS 20/10x1x315	315	20	10	8	2.5	10	16	20	8	8	3	1
BKS 25/12x1x160	160	25	13	9.5	3	12	20	25	10	10	3	1
BKS 25/12x1x315	315	25	13	9.5	3	12	20	25	10	10	3	1

